

"SA" 120 M

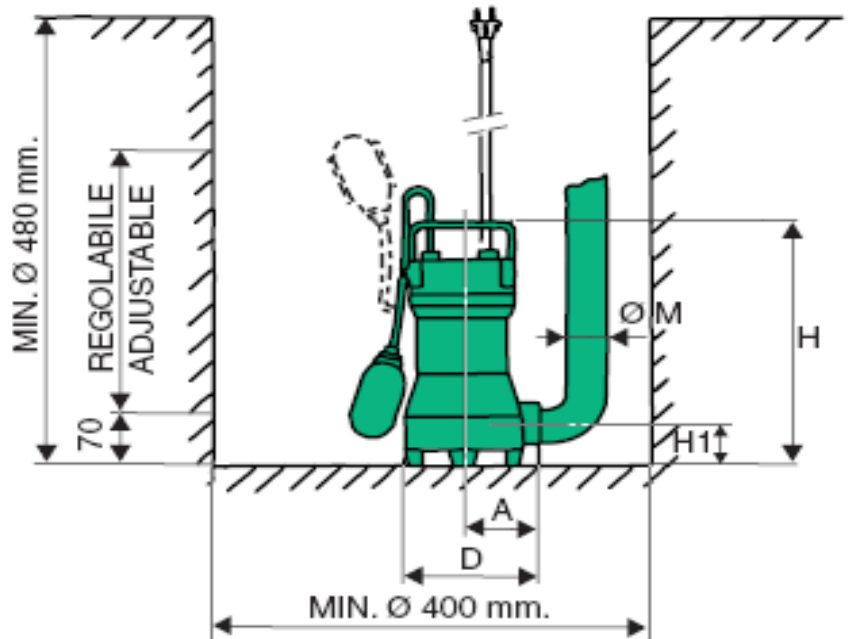

TIPO TYPE	DIMENSIONI [mm] DIMENSIONS [mm]					IMBALLO [mm] PACKING [mm]			PESO WEIGHT [kg]
	A	H1	H	D	ØM	A	L	P	
SA 120	98	65	380	170	1"1/4	420	210	175	19.3

TIPO TYPE	Potenza nominale Nominal power	Potenza assorbita Input power [W]	Condensatore Capacitor 450 V max	Corrente assorbita Input current [A]	Portata - Capacity																
					Q [m ³ /h]	Q [l/1']]	0	3	6	9	12	15	16.8	21.6	23.4	27					
Monofase Single-phase	Trifase Three-phase	kW	HP	a	b	[µF]	1~230V	3~400V	Prevalenza (m C.A.) Total head (m W.C.)												
a	b								H [m]	14.1	12.6	11.4	9.8	8.2	6.5	5.6	2.9				
SA 120 M	SA 120 T	0.88	1.2	1520	1470	25	6.8	2.6													

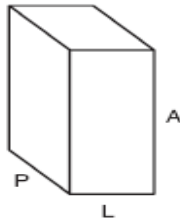